



OPERATIONS MANUAL

DEPOPULATION METHOD: CO₂

Prepared by:
Swine Medicine Education Center (SMEC)
Iowa State University
College of Veterinary Medicine

Funded by:
Iowa Department of Agriculture
and Land Stewardship (IDALS)

INTRODUCTION:

The AVMA Guidelines for the Depopulation of Animals: 2019 Edition states, “Carbon dioxide is a practical means for depopulation provided certain criteria are met to address the numbers and size of pigs and overall throughput.” The system described herein meets those criteria. In contrast to other options for mass depopulation, inhaled CO₂ gas has several advantages: it is mechanically simple (relative to v-restrainter and pneumatic captive bolt, for instance), it is reliable, repeatable (as demonstrated by this project), prevents blood contamination of the site, and it is scalable. It is important for the reader to understand that the procedure described herein is one option that meets AVMA criteria for the use of CO₂ as a means of depopulation. Alternative holding pen structures can be utilized that do not require concrete flooring and wooden penning. All methods of CO₂ euthanasia contain the following key components:

- A fully enclosed holding pen that is sized to minimize space not occupied by the pigs.
- A vaporization system that can be charged, filled or otherwise operated safely while pigs are loaded into the holding pen or carcasses are moved out of the holding pen by personnel.
- Consideration of the disposition of the gas.
- Safety procedures to prevent personnel exposure to carbon dioxide gas.

The particular variation described here relies on passive vaporization and developed in an iterative manner after the observation of resources at <http://www.ncagr.gov/oep/MassDepop.htm> and elsewhere and with the goal of addressing regional specifics of Midwest production systems.

AERIAL VIEW - STRUCTURE OUTLINE

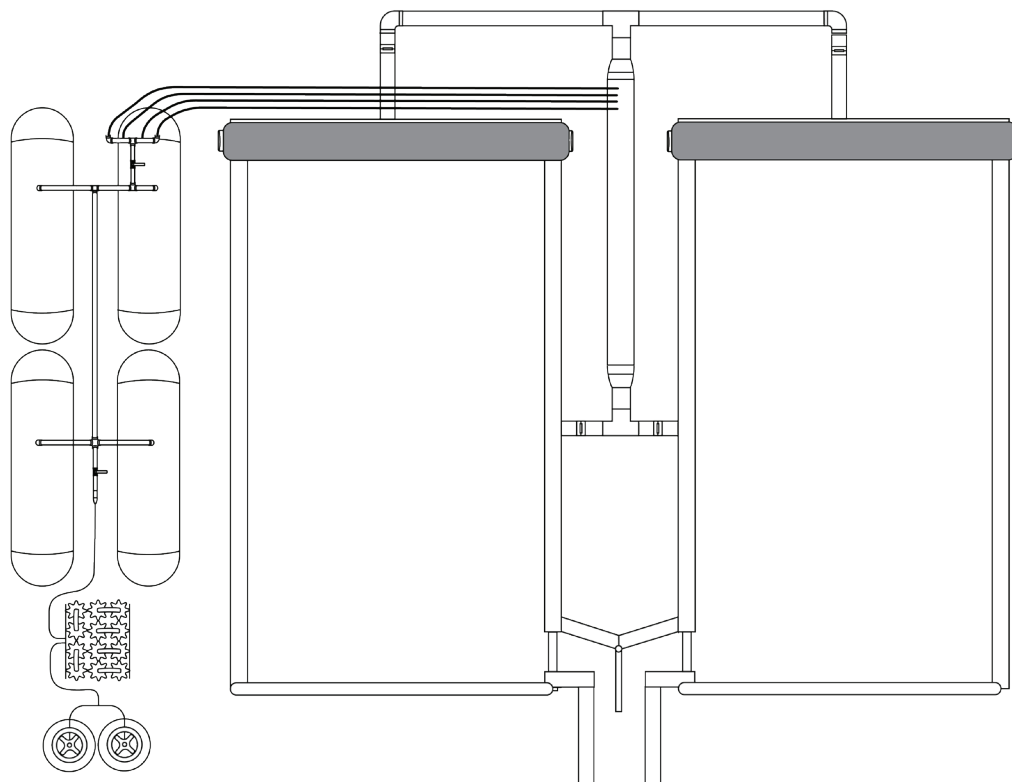

INTRODUCTION:

It is important to note that this manual describes the system as built and tested but also includes suggestions for modification moving forward. In fact, all participants agree that the CO₂ vaporization strategy is superior to our prior knowledge state and is the preferential system that should be used if needed in the future. However, the pig chamber/penning described here is one of many possible variations, most of which would be more portable, less expensive, faster to construct/adapt, and most would allow higher throughput efficiency than the fixed wooden corral described here. It is also important to note that the fixed wooden corral with concrete floor described here requires specialized construction skill to level the build site, align and set posts, frame, reinforce, and pour concrete flooring. The complexity of this construction is not described in this manual but is readily obtainable from agriculture building enterprises in the Midwest.

Costs are, therefore presented for the unit as built, and also for the CO₂ vaporization and administration apparatus without a pen/chamber to accommodate future planning that might include a preferred pen/chamber. Tools, personnel, safety, assembly instructions, timelines and expectations do not include the construction of the permanent wood and concrete pen/corral.

TABLE OF CONTENTS:

SUPPLIES & PERSONNEL	5
PARTS	6
ASSEMBLY INSTRUCTIONS	8
SAFETY GUIDELINES.....	13
OPERATION INSTRUCTIONS	17
COST BREAKDOWN	25
PERFORMANCE EXPECTATIONS	27
RECOMMENDATIONS FOR STOCKPILE PREPARATION (IOWA)	28
DISCUSSION/OBSERVATIONS.....	29
PHOTO REFERENCES	32
RESOURCES	35

SUPPLIES & PERSONNEL:

TOOLS NEEDED:

- | | |
|---|---|
| <input type="checkbox"/> 15" adjustable (crescent) wrenches (2) | <input type="checkbox"/> Assorted Phillips screwdrivers |
| <input type="checkbox"/> 18" iron pipe wrenches (2) | <input type="checkbox"/> Teflon or PTFE gas line thread seal tape |
| <input type="checkbox"/> 12" channel lock | <input type="checkbox"/> PVC cement and purple primer |
| <input type="checkbox"/> Multipurpose hack saw (1) | <input type="checkbox"/> Safety vest |
| <input type="checkbox"/> Wood crosscut handsaw (1) | <input type="checkbox"/> Safety CO ₂ monitors |
| <input type="checkbox"/> Assorted slotted screwdrivers | |

TOTAL PEOPLE NEEDED:

MINIMUM OF 5

- 2 people to load pigs
- 1 person to watch psi gauge
- 1 person to check for insensibility and death
- 1 safety manager

PARTS:

QUANTITY	SIZE / NAME	
<input type="checkbox"/>	2	180 liter / 400 lbs CO ₂ tanks (A)
<input type="checkbox"/>	1	CO ₂ vaporizer (B)
<input type="checkbox"/>	4	1000 gallon propane tanks (C)
<input type="checkbox"/>	1	2" x 1/2" pipe (D)
<input type="checkbox"/>	1	1/2" - 1/4" reducer (E)
<input type="checkbox"/>	1	2 1/4" pipe (F)
<input type="checkbox"/>	1	2 1/4" ball valve (G)
<input type="checkbox"/>	2	6" threaded 1 1/4" pipe (H)
<input type="checkbox"/>	1	1 1/4" cross (I)
<input type="checkbox"/>	1	1 1/4" pipe (J)
<input type="checkbox"/>	4	1 1/4" union (K)
<input type="checkbox"/>	6	1 1/4" 90° elbow (L)
<input type="checkbox"/>	1	1 1/4" ball valve (M)
<input type="checkbox"/>	5	1 1/4" tee (N)
<input type="checkbox"/>	4	1 1/4" - 3/4" bushings (O)
<input type="checkbox"/>	4	3/4" barbed hose fitting (P)
<input type="checkbox"/>	4	3/4" dishwasher hose (Q)
<input type="checkbox"/>	8	1" hose clamps (R)
<input type="checkbox"/>	4	1/4" barbed hose fitting (S)

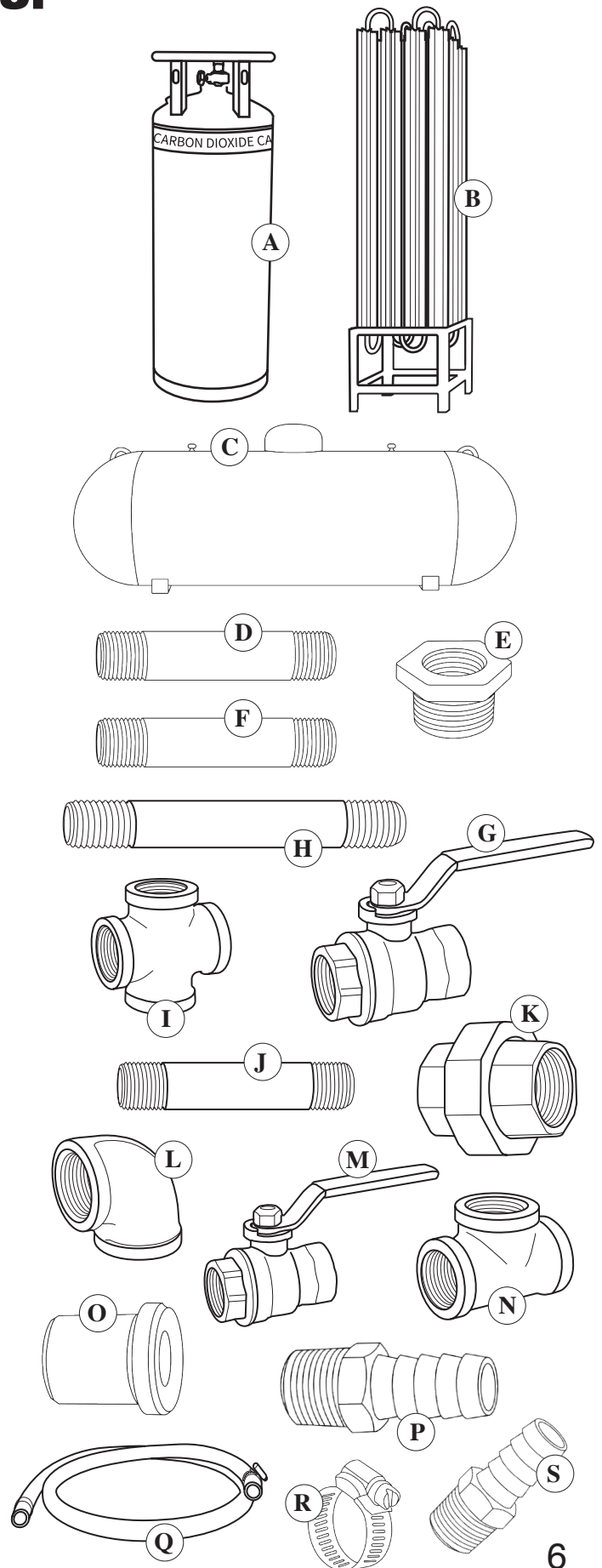

PARTS:

Quantity	Name	
<input type="checkbox"/>	4	4" pipe (T)
<input type="checkbox"/>	4	4" gate valve (U)
<input type="checkbox"/>	2	4" PVC elbow (V)
<input type="checkbox"/>	2	4" PVC tee (W)
<input type="checkbox"/>	2	50' x 16' tarp (X)
<input type="checkbox"/>	1	PVC brace (Y)
<input type="checkbox"/>	80	screw hooks (Z)
<input type="checkbox"/>	1	rope (a)
<input type="checkbox"/>	40	wooden posts (b)
<input type="checkbox"/>	2	gates (c)
<input type="checkbox"/>	6	wooden boards (to support tarp) (d)
<input type="checkbox"/>	2 inch thick treated boards sufficient to cover pen walls (40' long x 10' wide x 4.5' tall)	
<input type="checkbox"/>	4' x 8' sheets of glass board (to cover gates)	
<input type="checkbox"/>	Caulk sufficient amount to cover pen walls (40' long x 10' wide x 4.5' tall)	

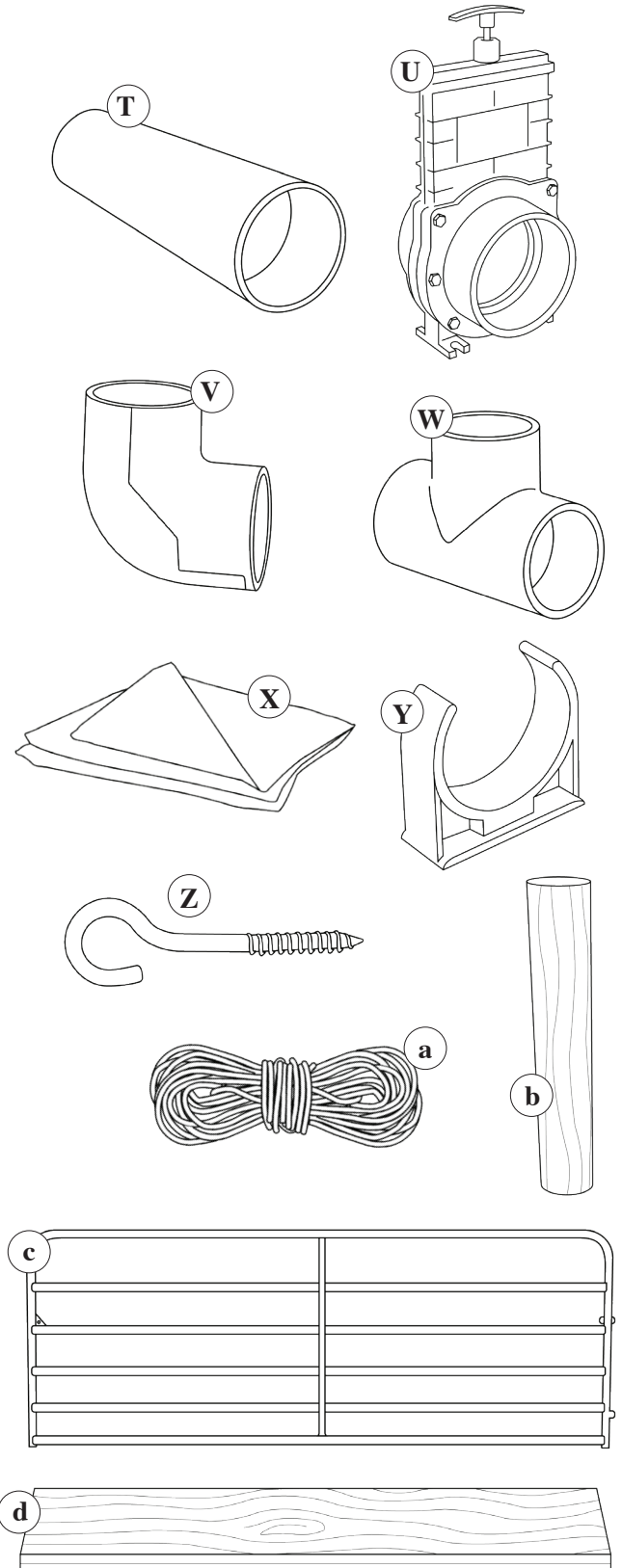

ASSEMBLY INSTRUCTIONS:

After obtaining all of the necessary parts, assembly can begin. Below is a diagram of the overall set up.

AERIAL VIEW - STRUCTURE OUTLINE

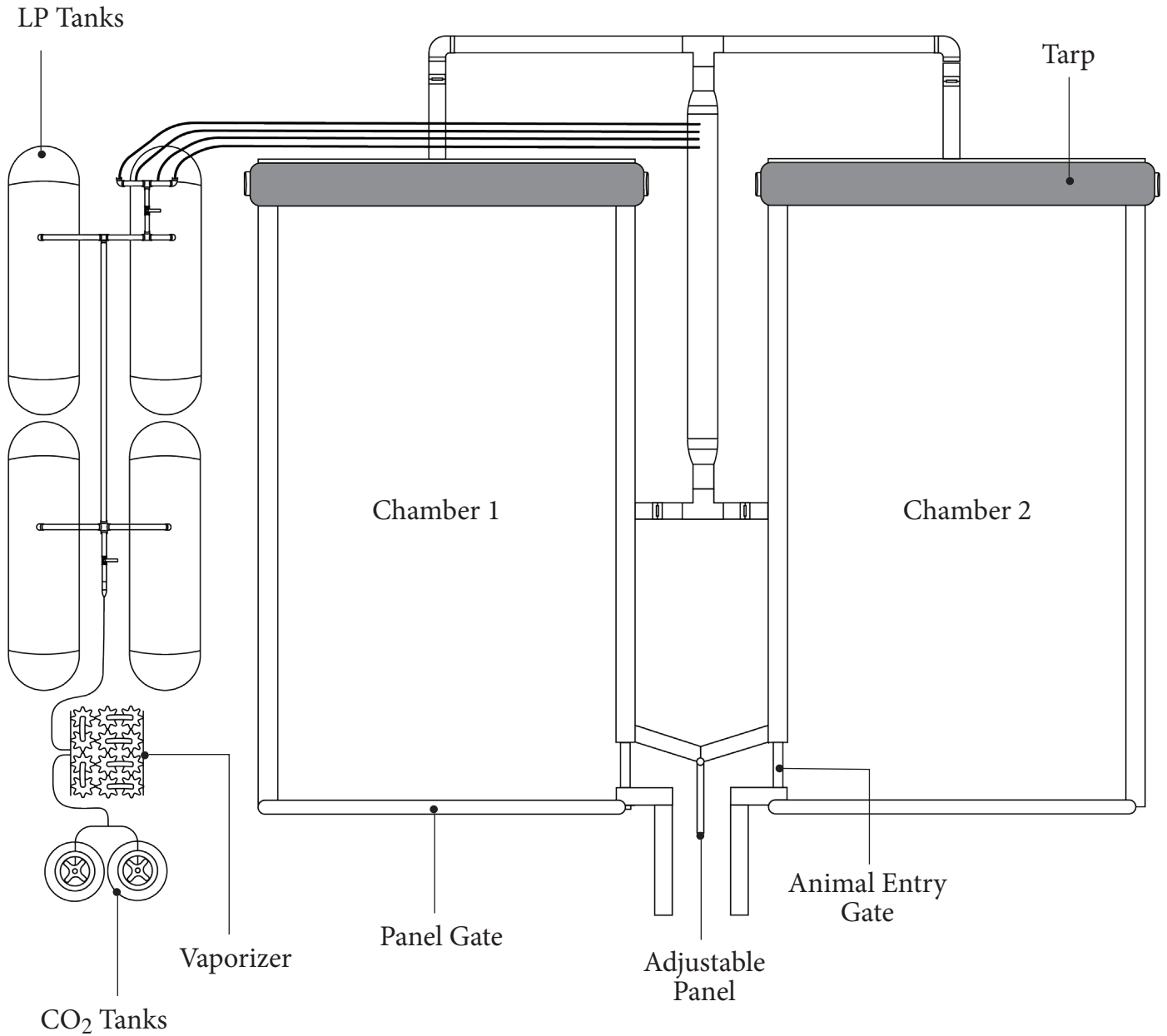

Detailed diagrams can be found on the following pages.

ASSEMBLY INSTRUCTIONS:

CHAMBER SET UP

The figure below shows a diagram of the chambers. Chamber dimensions:
Each chamber is 40' long x 10' wide x 4.5' tall

AERIAL VIEW

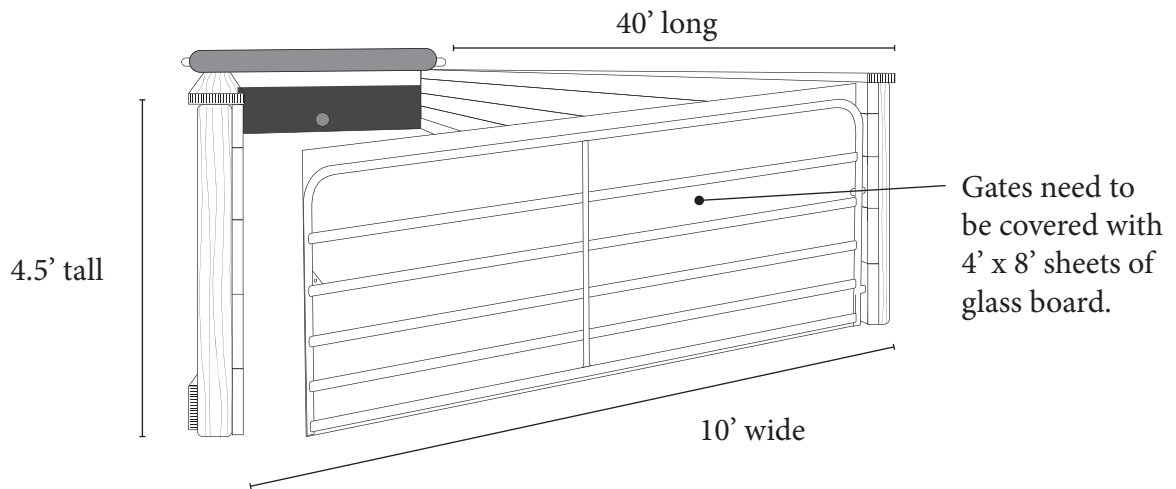
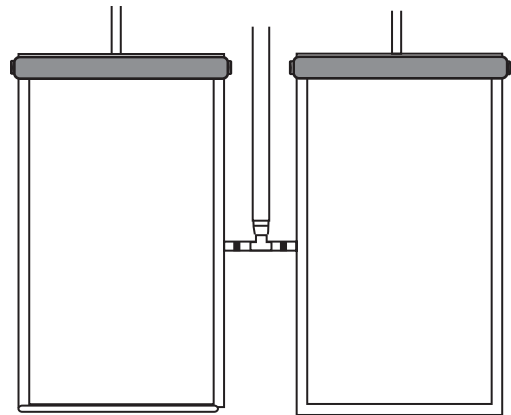

CHAMBER - OPEN TARP - SIDE GROUND VIEW

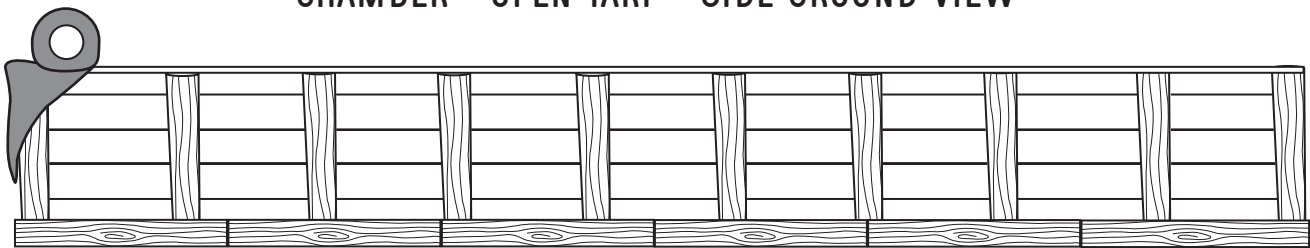

CHAMBER - CLOSED TARP - SIDE GROUND VIEW

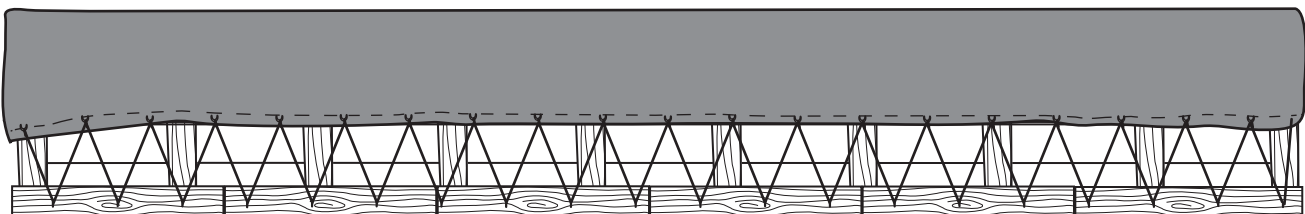

ASSEMBLY INSTRUCTIONS:

CONNECTION FROM LP TANKS TO PVC PIPING TO CHAMBERS

The figure below shows an aerial view diagram of the PVC piping from the LP tanks to the two chambers.

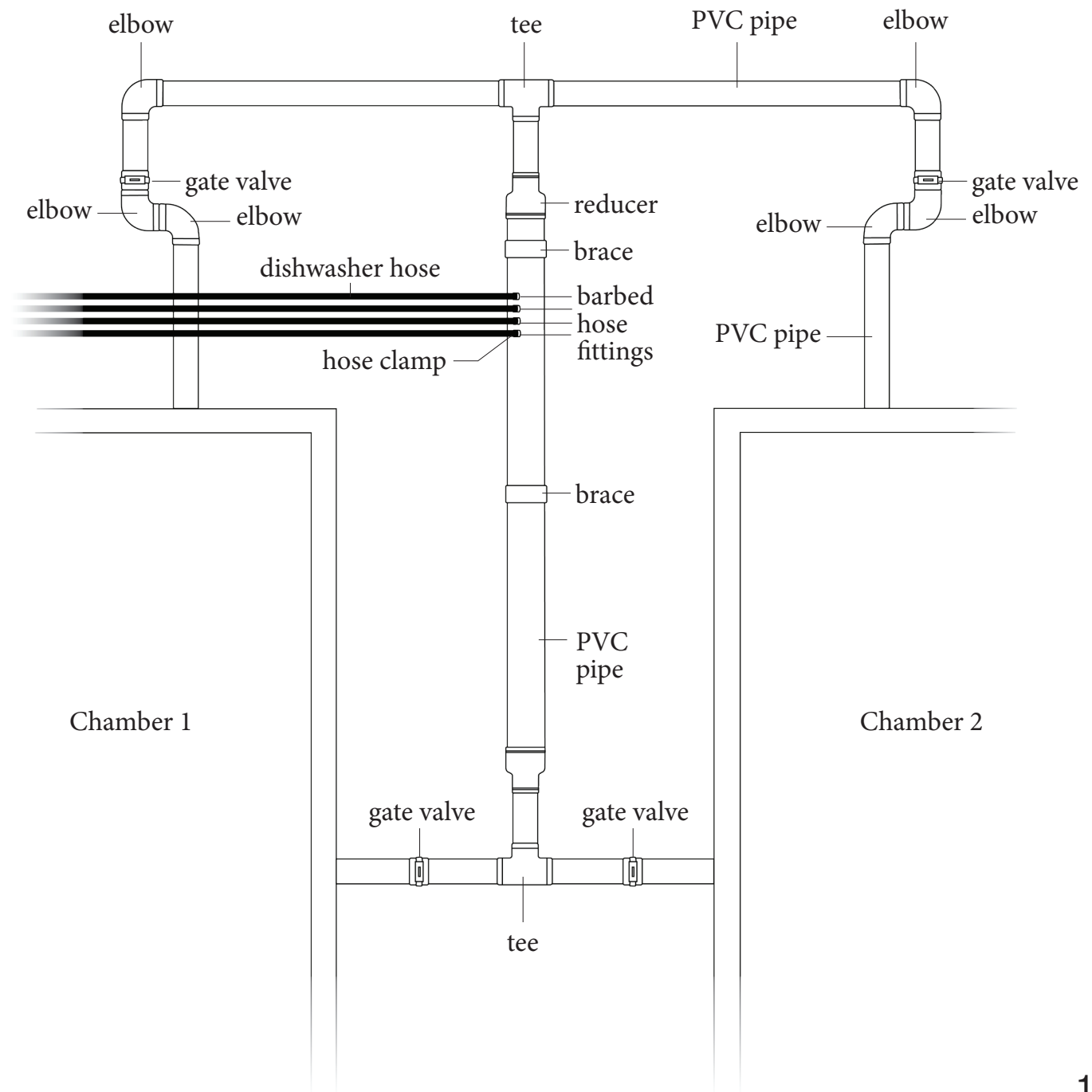
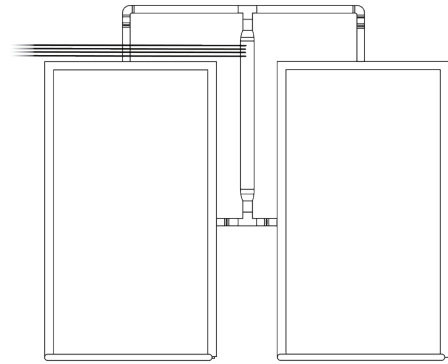

ASSEMBLY INSTRUCTIONS:

The figure below shows a diagram for connecting the CO₂ tanks to the vaporizer.

GROUND LEVEL VIEW - CONNECTION FROM CO₂ TANKS TO LP TANKS

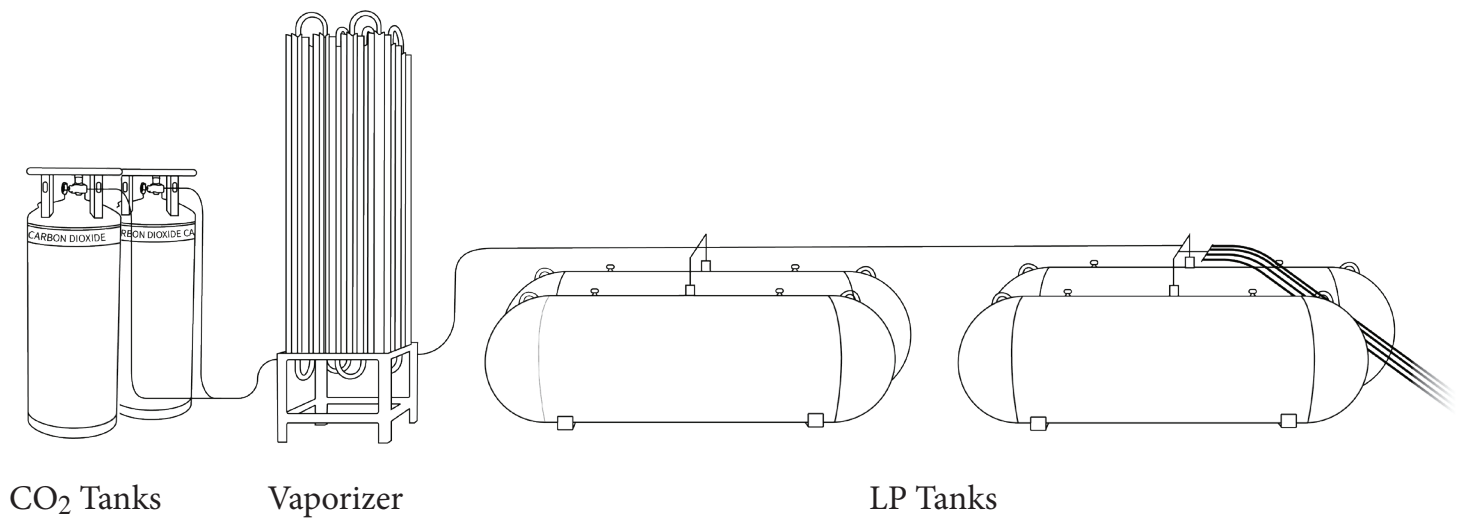

AERIAL VIEW

CO₂ Tanks

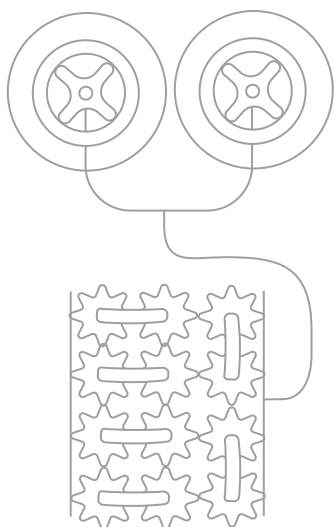

Vaporizer

CONNECTION FROM CO₂ TANKS TO VAPORIZER

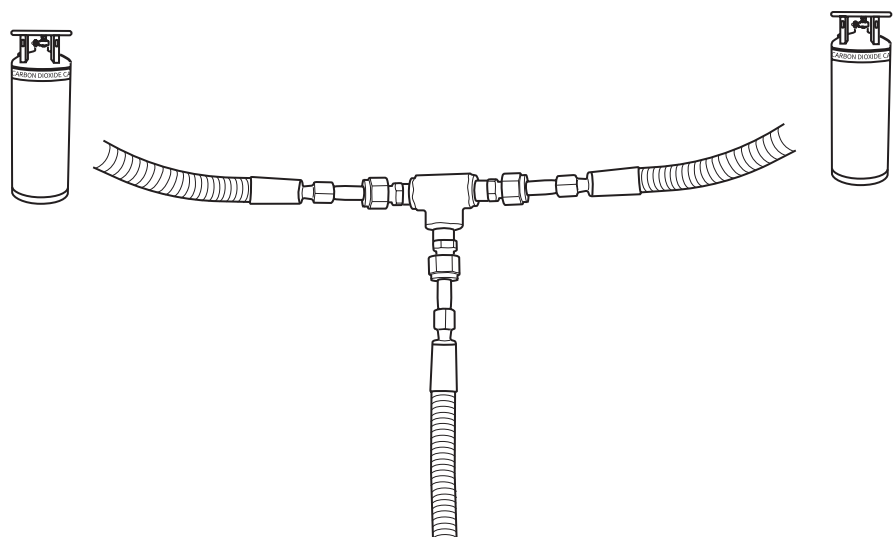

ASSEMBLY INSTRUCTIONS:

CONNECTION FROM VAPORIZER TO LP TANKS

The figure on the right shows an aerial view diagram of the metal piping from the CO₂ vaporizer jacketed vacuum hose to the LP tanks. The diagram ends with the dishwasher hoses, which will attach to the PVC piping in the diagram on the next page.

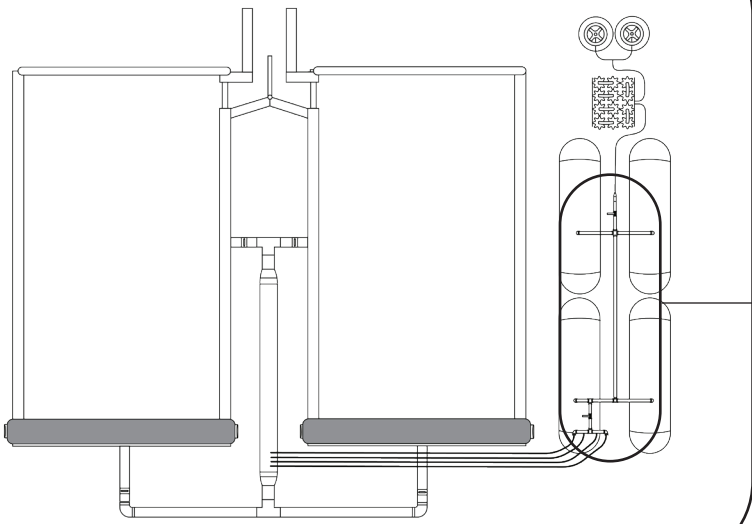

AERIAL VIEW

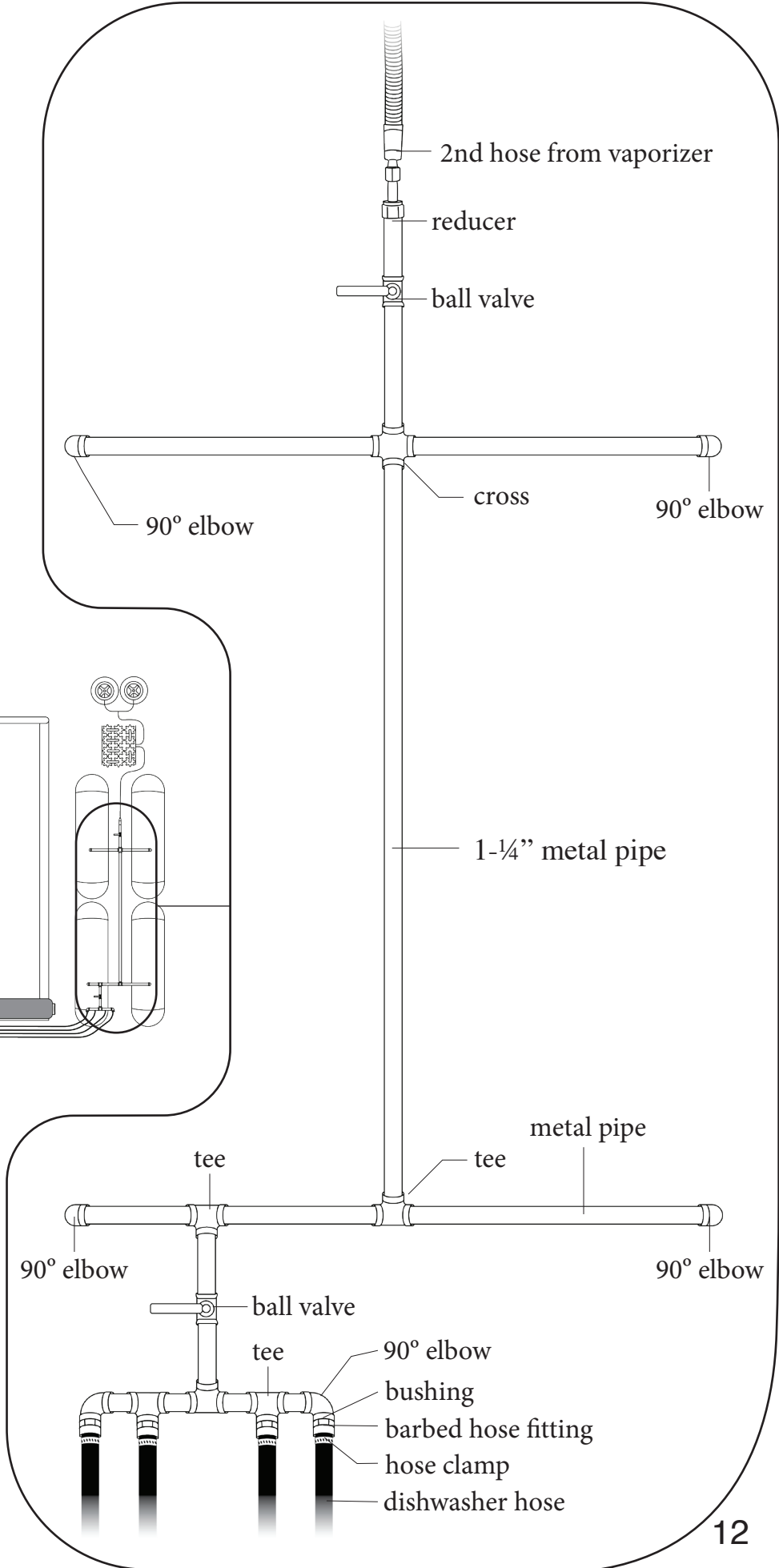

SAFETY GUIDELINES:

⚠ WARNING:

Carbon dioxide (CO₂) is an odorless, colorless, non-flammable gas that is also found in solid and liquid forms. Outdoor air levels typically range from 300 – 500 ppm. **Exposure to extreme CO₂ concentrations, as used in this method, can lead to death.** CO₂ will displace all of the air in the depopulation container. Ensure that the container is adequately ventilated before individuals enter.

CARBON DIOXIDE LEVELS AND EFFECTS ON HUMANS

PPM	%	Effects
10,000	1.0	Possible drowsiness
15,000	1.5	Mild respiratory stimulation
30,000	3.0	Moderate respiratory stimulation, increased heart rate and blood pressure
40,000	4.0	Immediately dangerous to life or health
50,000	5.0	Strong respiratory stimulation, dizziness, confusion, headache, shortness of breath
80,000	8.0	Dimmed sight, sweating, tremor, unconsciousness, and possible death

There are six broad categories of potential safety hazards for personnel operating carbon dioxide mass depopulation as described in this manual: 1) direct gas exposure, 2) high pressure equipment malfunction/failure, 3) fractious animal / human interactions, 4) mechanized equipment exposure/operation, 5) deployment of backup euthanasia tools and 6) psychological stress. The circumstances and specific precautions for each will be addressed after describing some general over-arching safety precautions that are relevant for all six categories. The following are key considerations for all categories of hazards:

- While everyone is accountable for safety, the project personnel should include a designated safety manager with authority to stop the process at any point if a hazard is identified. This person should be clearly designated and indicated by colored vest, hat or uniform. They should have complete working knowledge of all parts of the project. Their function is intense, focused observation of the steps of the process with a goal of identifying hazards that are inherent or arise from inappropriate procedures. The safety manager should have a means of working communications, first aid kit, be previously trained in basic life support (BLS) and CPR, and know the location of the nearest hospital in the region.

SAFETY GUIDELINES (CONT)

- All components described in this project should be conducted outside and no additional surrounding structure, tent, or outbuilding should be built to enclose the carbon dioxide source tanks, carbon dioxide vaporizers, handling equipment or animal pens.
- Observers other than the safety manager should remain at least 15 yards from the perimeter of the equipment and pens. This is referred to as the ‘safety perimeter’ in further context.
- All personnel should be oriented to potential hazards at the start of operation and should also be instructed on the expected behavior of the carbon dioxide gas especially that it is denser than air and could be wind driven, especially when pens are first re-opened. There is no risk of ignition or fire due to carbon dioxide concentration.

Specific risks and preventions are described below. Further, any manuals included with components of the system or equipment should be reviewed and the safety guidelines described therein followed in addition to the considerations here.

(1) Direct carbon dioxide gas exposure considerations:

- Everyone involved in the process should wear a personnel carbon dioxide monitor. In the process described in this manual, personnel wore a monitor with the following specifications:
 - CO₂ measurement range: 0-5% (0-50,000ppm) CO₂.
 - CO₂ sensor accuracy: $\pm 70\text{ppm} \pm 5\%$ reading value.
 - CO₂ measurement interval: 2 seconds.
 - Audible alarm: 90 db @ 10 cm.
 - The device should also include a strobe and vibrating alarm for personnel operating loud equipment in the pen area for carcass removal.
 - The device should also include a “person down alarm” which triggers the audible alert when an employee falls.
 - Operational temperature range: 32°F to 122°F.
 - Note that an operational range appropriate for colder temperatures in winter may be necessary.
 - Operational humidity range: 0-95% RH, non-condensing.
 - Size: 2.0 x 4.0 x 4.0 in. (50.8 x 101.6 x 101.6mm.) and weight: 0.25 lb (4 oz.).
 - Monitors are available that are battery operated and/or rechargeable. Care must be taken to make sure charging equipment or spare batteries are stocked at the depopulation site.
 - The device used in the activities described in this manual was the SAN-10 Personal 5% CO₂ Safety Monitor and Data Logger. The associated manual and brief operational video can be found here: <https://www.co2meter.com/collections/handheld/products/personal-co2-monitor>
- When the carbon dioxide monitor of any personnel is triggered, activity is halted until that person is in a safe location and status.

SAFETY GUIDELINES (CONT)

- Everyone should be aware of wind direction and where the windward and lee sides of the pens are located before starting.
- Vaporization of liquid carbon dioxide is endothermic and may freeze pipes, valves and tanks including accumulation of frost layers on those surfaces. Care should be taken to avoid direct skin contact with these surfaces to avoid injury.
- No one enters the pens at any time without first notifying the safety manager.
- Pens are completely opened (tarp rolled back and all animal and human entry gates opened) and allowed to vent for at least 5 minutes before any personnel enter the pens.
- Anyone experiencing dizziness, light-headedness, shortness of breath, increased respiratory rate not consistent with physical effort, or headache should be removed to beyond the safety perimeter on the windward side of the equipment and penning structure.
- When reusing LP tanks for vaporizing the carbon dioxide, an insignificant but noticeable smell of hydrogen sulfide may be occasionally perceived. This should be construed as a signal that the person is being exposed to carbon dioxide and they should alert the safety manager, move from the area and consider if the potential source is indicative of system leak or malfunction.
- If a person loses consciousness, the area should be vented immediately to make it safe for emergency care, the victim should be removed to beyond the safety perimeter as soon as safe to do so, BLS/CPR should be initiated immediately and emergency services contacted.

(2) High pressure equipment malfunction/failure considerations:

- Liquid carbon dioxide has a vapor pressure of ~830 PSIG. All carbon dioxide tanks, hoses, fittings and valves from the liquid carbon dioxide tank through to the gas side of the vaporizer should be rated for this pressure and constructed of material that remains operational at -110°F. These items should be purchased from the carbon dioxide supplier if possible.
- The liquid carbon dioxide tank, vaporizer and LP tanks should each have functioning pressure relief valves that will release pressure below the tank/vaporizer rated pressure capacity limit to prevent catastrophic rupture.
- Pipe joint and equipment integrity should be visually inspected at the start of each pressure event by the safety officer.
- If leaks are detected or pressure valves activated, the valve at the liquid carbon dioxide source should be shut immediately until repairs are made.
- If indications of gas flow (as described in the operations section) cease prematurely and an ice plug is suspected, the valve at the carbon dioxide source should be shut immediately, and the system allowed to warm until the ice plug resolves. Heating frozen connections, pipes or valves with a torch or other device is not recommended as the supplemental heat may impact the joint or vessel integrity.
- LP tanks with warranty, serial numbers, and data plates intact should be used and the rated pressure not exceeded.

SAFETY GUIDELINES (CONT)

(3) Fractious animal / human interaction considerations:

- Animal handling and movement should be reserved for personnel previously experienced with animal interaction and familiarity with industry standards for animal loading, unloading and movement.
- Animal handling personnel should be NPB - PQA and TQA certified.
- Sort boards of appropriate size should be used between the animal handler and the animals.

(4) Mechanized equipment exposure/operation considerations:

- Mechanized equipment hazards are primarily incurred through the use of livestock trailers to transport pigs to the mass depopulation pens and the use of loaders and trucks to remove carcasses after the use of the carbon dioxide gas. These hazards consist primarily of the risk of blunt force trauma, crushing, entrapment in pinch points of equipment, and exposure to exhaust fumes that contain carbon monoxide. These hazards are not specific to the carbon dioxide mass depopulation process outlined in this manual.
- The safety manager should remain diligent during the unloading of live pigs and the removal of carcasses.
- Personnel not operating equipment or serving as safety manager should remain beyond the safety perimeter during loading and unloading of animals and carcasses.
- Equipment safety features should be kept intact and subjected to routine safety and maintenance checks as appropriate for the specific equipment used by the operator and owner of the equipment.

(5) Deployment of backup euthanasia tool considerations:

- Although not experienced during the development and operation of the system described in this manual, it is theoretically possible that fractious animals could become non-ambulatory during unloading from transport or incompletely euthanized in the pens during exposure to gas. An alternative, individual animal euthanasia technique approved by the American Veterinary Medical Association, such as penetrating captive bolt should be available in preparation for these potential adverse outcomes. Safety measures related to alternative methods of euthanasia should be reviewed and discussed with safety manager prior to start of depopulation event. Considerations associated with all of the possible techniques are beyond the scope of this manual. If you bring it, know how to use it safely.

(6) Psychological stress considerations:

- The psychological and emotional stress of euthanizing animals is well documented elsewhere. One can reasonably expect those stresses to be amplified due to mass depopulation, especially if the depopulation is necessitated by circumstances other than relieving animal suffering and pain. All personnel should be alert for signs that co-workers are struggling and work to create an empathetic and caring environment that allows for dissipation of emotional stress or provides an opportunity for affected personnel to remove themselves from the situation without negative consequences.

OPERATION INSTRUCTIONS:

HOW TO OPERATE CO₂ CHAMBERS

NOTE: These specific step-by-step instructions assume that the CO₂ system is assembled but may have been assembled by someone other than the operator. Complete assembly assumes that the first CO₂ tank is already connected. Once assembly is complete the CO₂ chambers are ready for operation.

1. Check all connections to ensure that they match the instructions and diagrams in this manual with focus on confirming that connections are secure and pathways for pigs and CO₂ are not impeded.
2. Locate the pressure valve for the LP tanks and confirm that it indicates no pressure in the LP tanks. If it indicates pressure, open all valves between the LP tank and the animal containment pens to vent residual pressure.
3. Ensure ball valve to dishwasher hoses is closed.

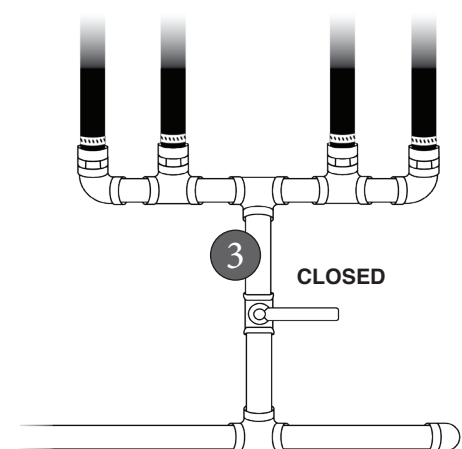
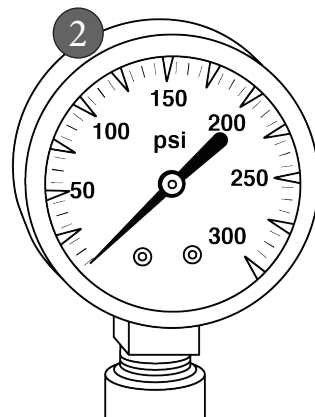
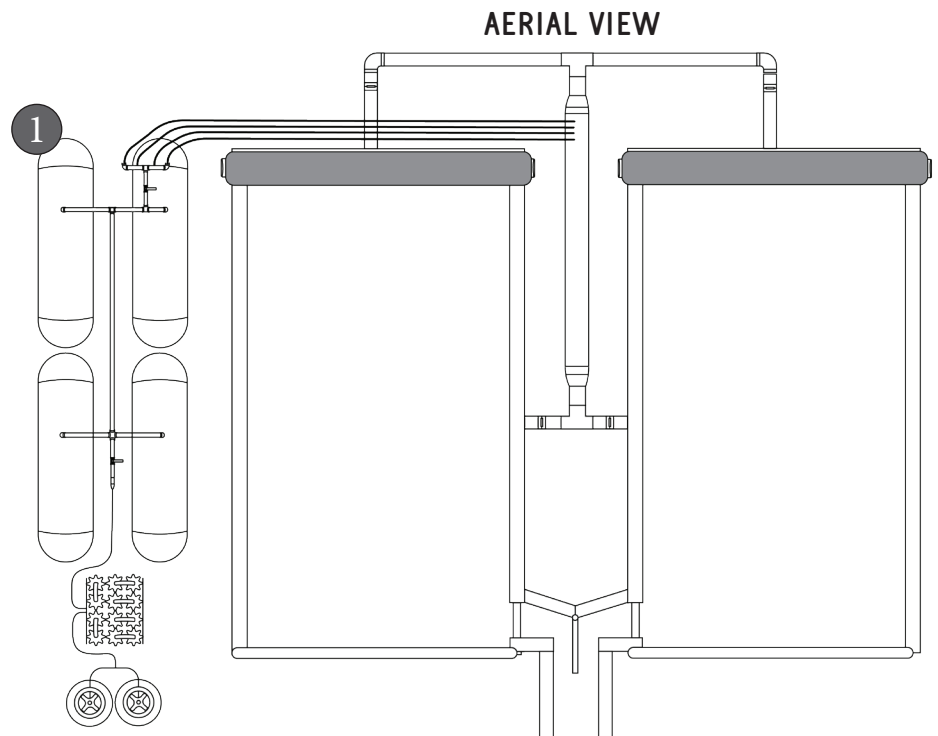

OPERATION INSTRUCTIONS:

HOW TO OPERATE CO₂ CHAMBERS

4. Ensure PVC gate valves to chambers are pushed down which indicates they are closed.
5. Open valve between CO₂ vaporizer to LP tanks.
6. Confirm that high pressure connection from vaporizer to CO₂ supply tank is connected to the “liquid” output valve on the CO₂ supply tank (not the “vapor” or “gas” output valve).
7. Slowly open valve from liquid CO₂ tank(s) to vaporizer. There should be one or more auditory indications of CO₂ movement into the vaporizer including whistling or a sound similar to flowing water along with expansion and contraction (clicking or pings) of vaporizer, lines to LP tanks, and LP tanks. If not confirm that all valves along the pathway between the CO₂ tanks and the LP tanks are open. As the CO₂ level equals the auditory whistling will diminish.

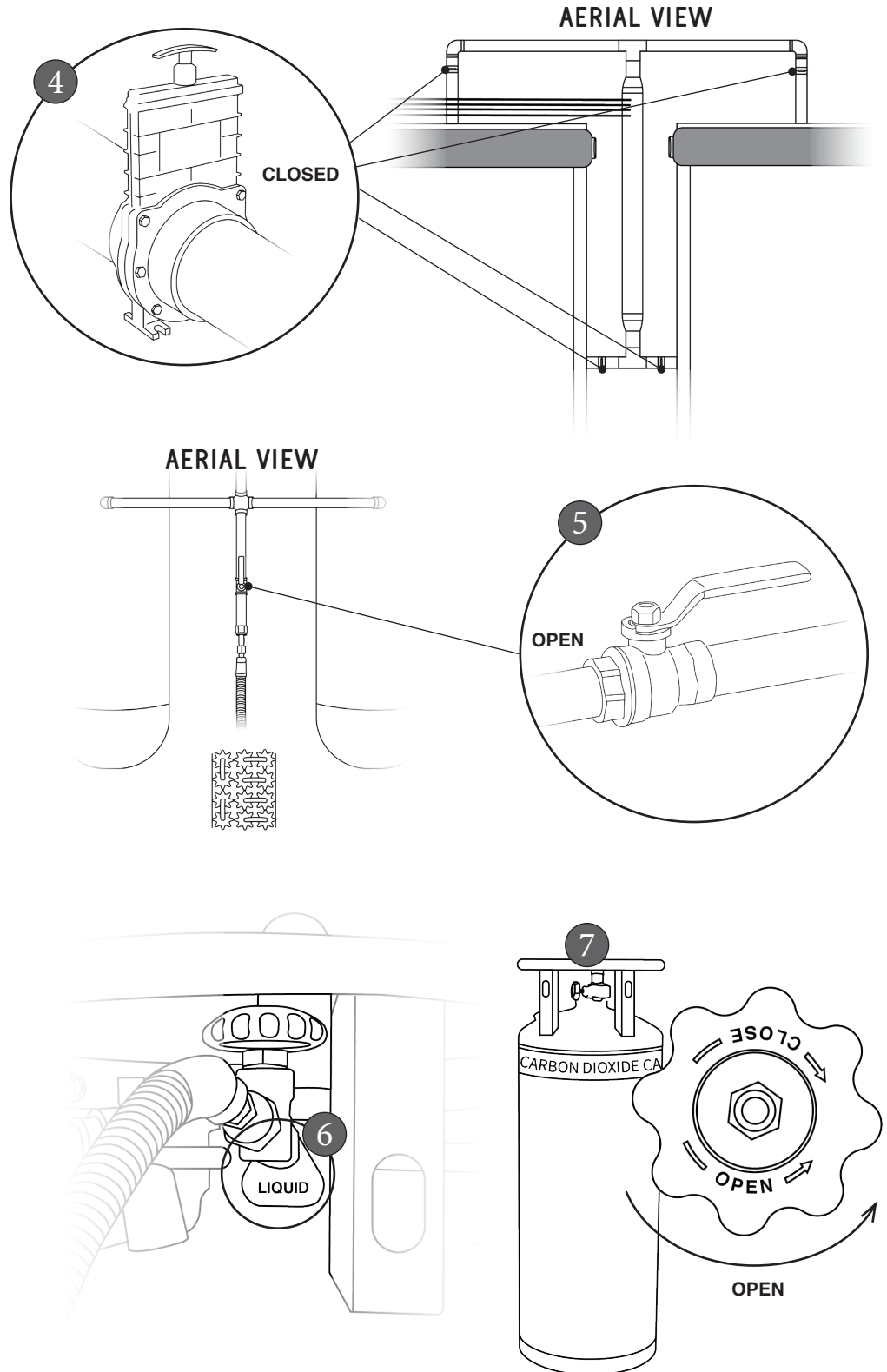

OPERATION INSTRUCTIONS:

HOW TO OPERATE CO₂ CHAMBERS

8. Confirm visual indications of CO₂ movement through the system including condensation and or frosting of pipes leading to the vaporizer and of the vaporizer itself.

NOTE: If frosting of the vaporizer occurs all the way to the output of the vaporizer, partially close the “liquid” valve on the CO₂ supply tank.

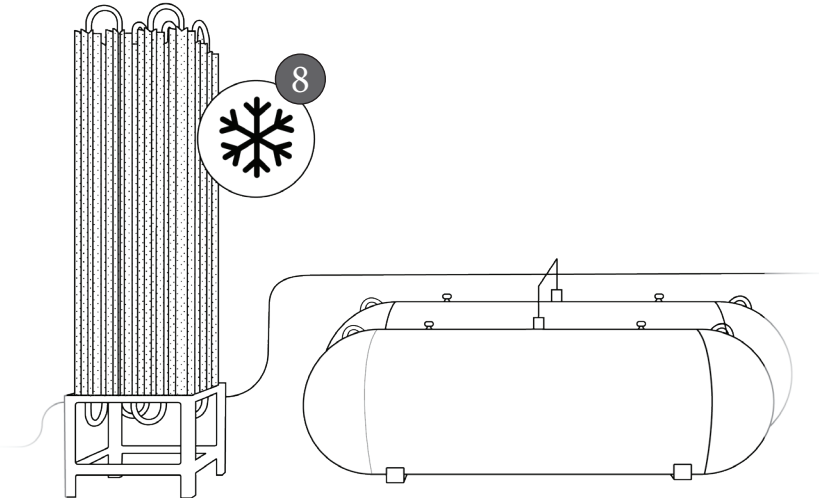

9. Designate a person to watch the propane tank pressure gauge. Confirm that pressure is increasing in the LP tanks using the attached pressure valve. Allow LP tanks to fill to desired pressure of 55psi.

NOTE: Refer to pages 29-30 of manual that describes pressure target calculation for various pen sizes if using an alternative pen from that described in this manual.

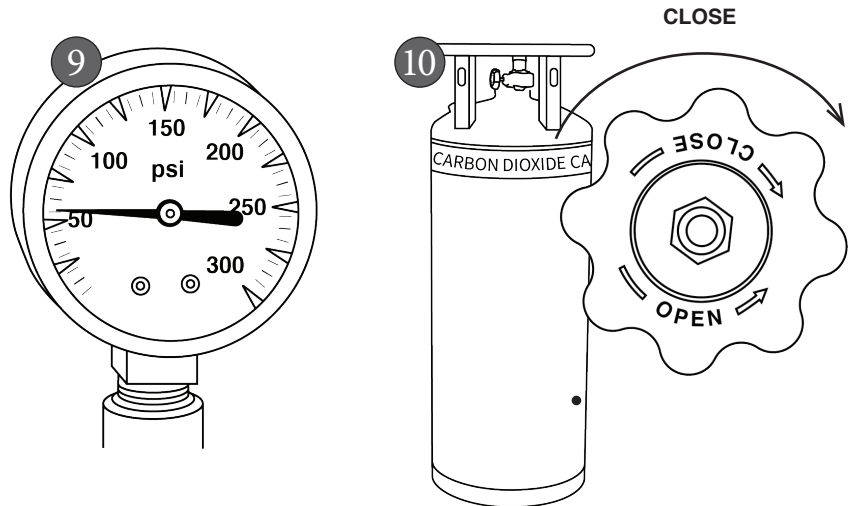

10. Once target pressure is reached in LP tanks, close the “liquid” valve on the CO₂ source tank.

11. Attach or replace the wooden boards (3) that support the tarp across the top of the container. These are removed to allow for the entry of mechanical loader equipment that removes carcasses.

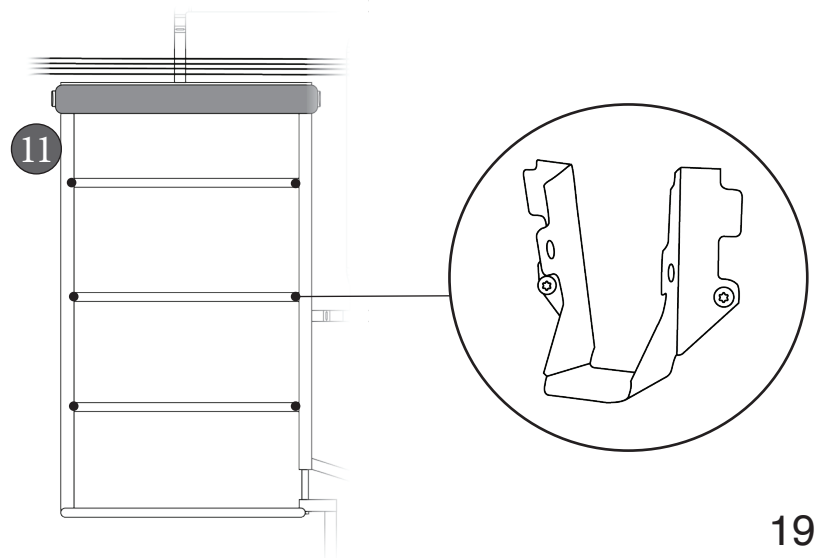

OPERATION INSTRUCTIONS:

HOW TO OPERATE CO₂ CHAMBERS

12. Ensure that the front large panel gate to the chamber is closed and secured. This gate is opened to allow equipment to remove carcasses.

13. Set up alleyway from trailer to pig chamber for movement of live animals.

14. Load pigs from trailer into chamber.

15. Close animal entry gate to chamber.

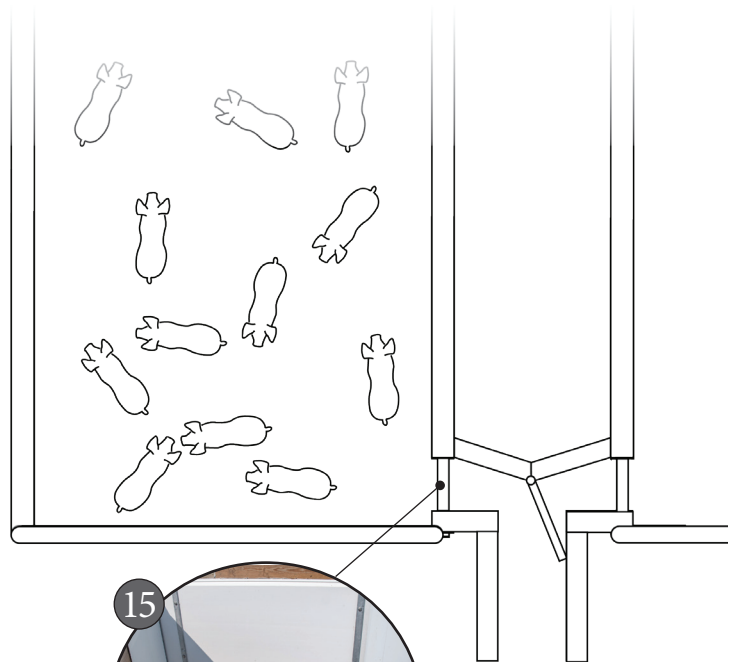
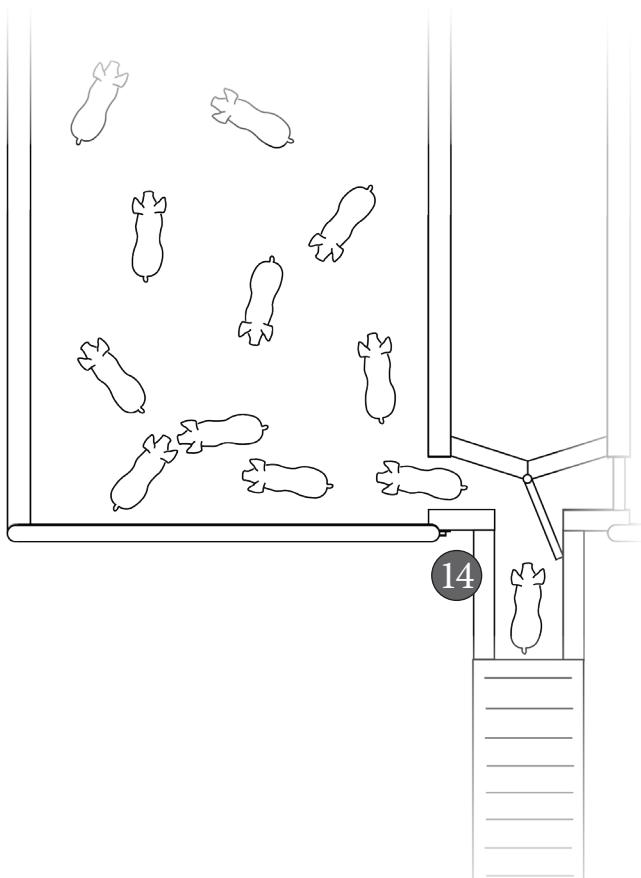
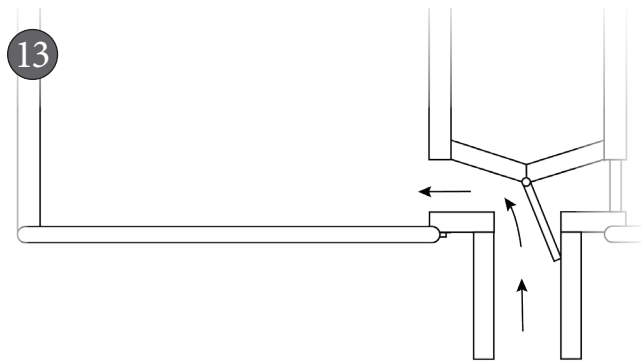
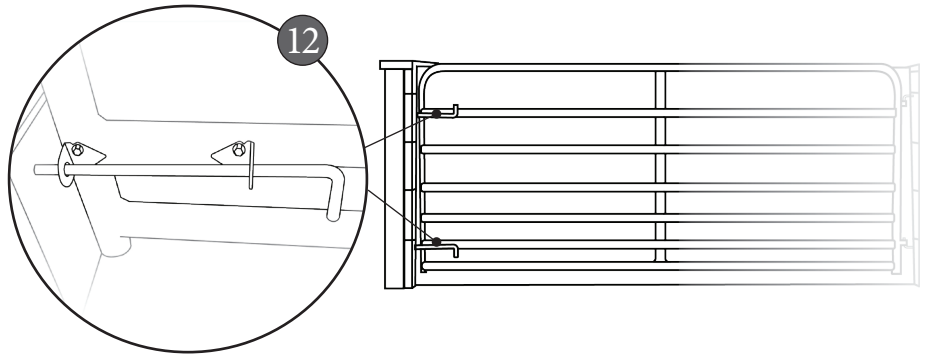

OPERATION INSTRUCTIONS:

HOW TO OPERATE CO₂ CHAMBERS

16. Roll tarp over the top of the chamber and secure ropes to hooks near the ground on both sides of the tarp. When tying down the tarp be sure to start at the back end away from the load out and work forward to keep strings tight. When the end of the ropes are reached be sure to tie off the rope at the last anchor point.

NOTE: Gas and exhaust air leaves the pens from the space above the animal entry gate so avoid this area during filling.

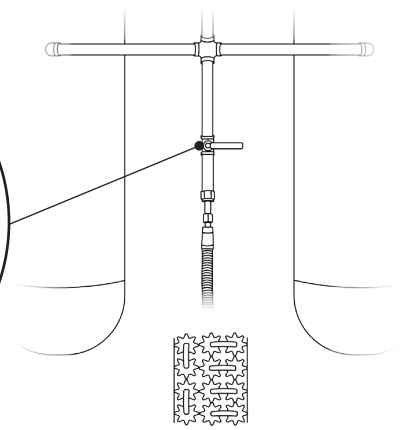
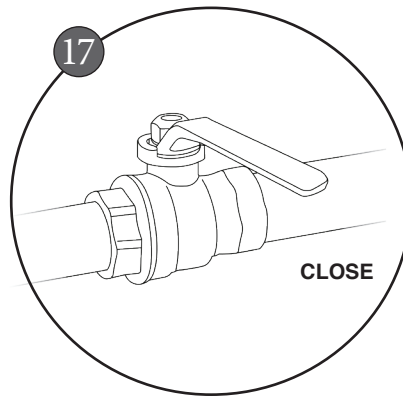
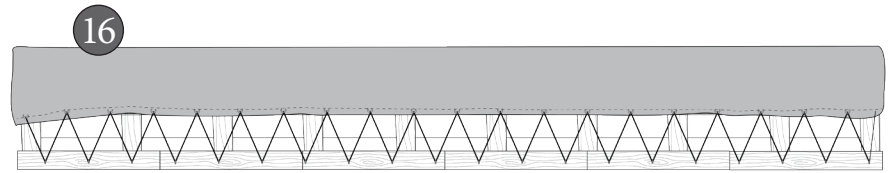

17. Close valve from vaporizer to LP tanks.
18. Open PVC gate valves to appropriate chamber containing pigs.
19. PARTIALLY open ball valve from LP tanks to dishwasher hoses. Note there should be one or more auditory indications of gas movement into the PVC pipes and chambers including a sound similar to flowing water along with expansion and contraction (clicking or pings) of PVC lines to chambers. If not, confirm that all valves along the pathway between the LP tanks and animal chambers are open.

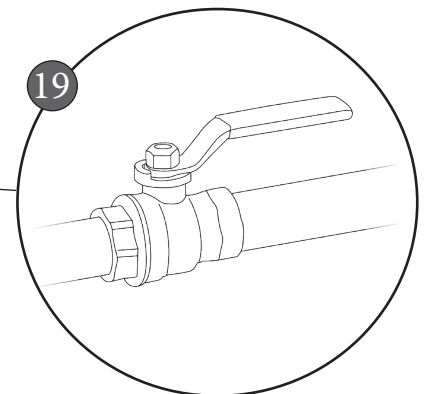
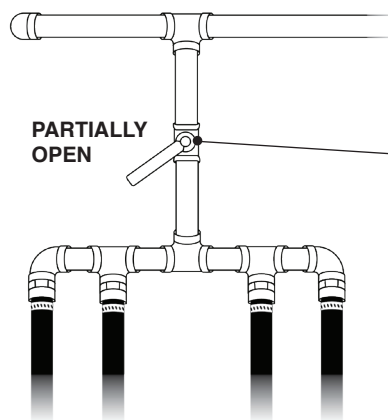
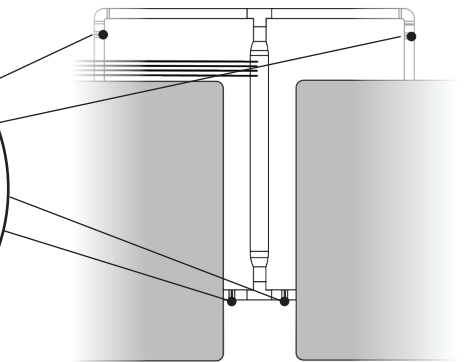
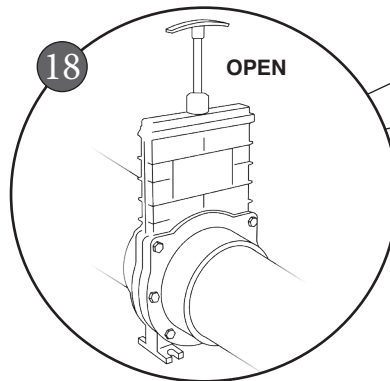

OPERATION INSTRUCTIONS:

20. Allow CO₂ to enter the chamber over the first 5 minutes by steadily increasing the opening of the ball valve to allow approximately 20% (approximately 10-11 pounds per minute) of the pressure to subside each minute. After the first five minutes, open the valve completely and begin the dwell time period.

NOTE: “a CO₂ displacement rate of 20% of the container volume/min for 5 minutes will result in unconsciousness within 2 minutes and death within 10 minutes.” (AVMA Guidelines for the Depopulation of Animals: 2019 Edition).

21. Listen for signs of animal activity which should peak at approximately 3 minutes and then quiet and cease by 10 minutes.

22. Roll back tarp and visually observe all pigs for any signs of consciousness while staying out of the chamber.

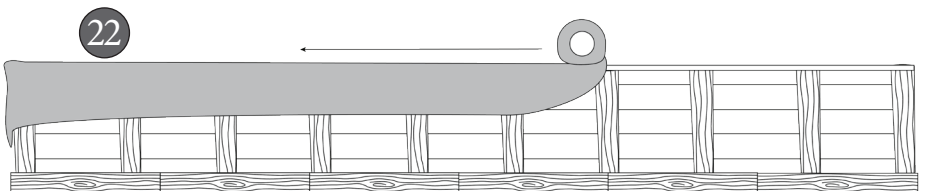
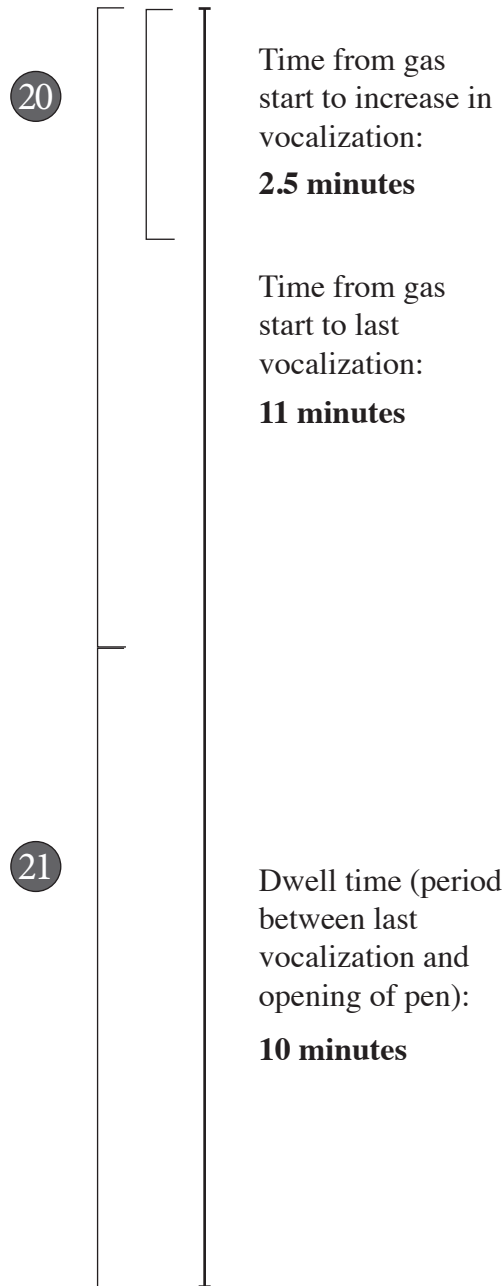

OPERATION INSTRUCTIONS:

23. Open gate and allow CO₂ to escape.

NOTE: CO₂ is heavier than air and will exit the front of the chamber once the gate is opened. Personnel should not stand in this area and safety protocols, including the appointment of a safety manager should be strictly observed.

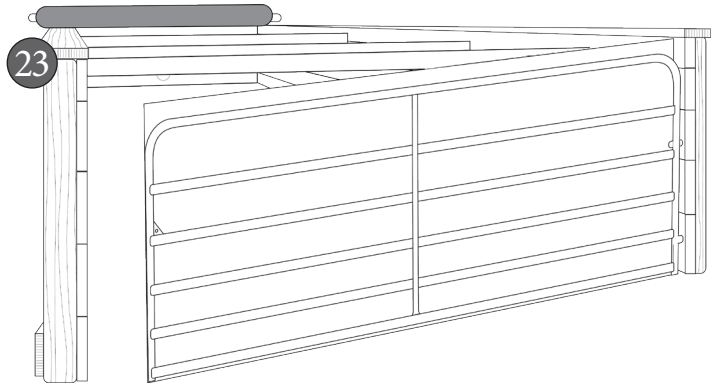

24. Remove boards across the top of the chamber.

25. Begin carcass removal.

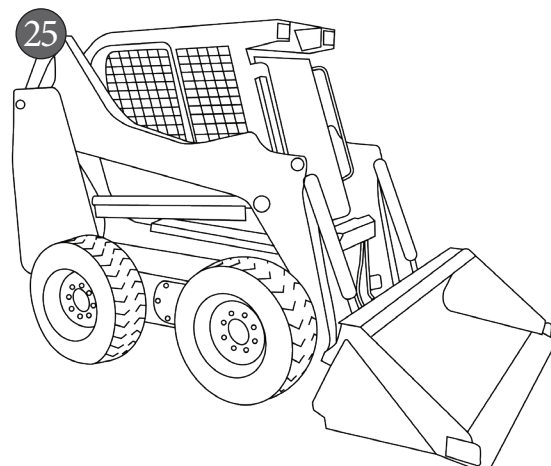
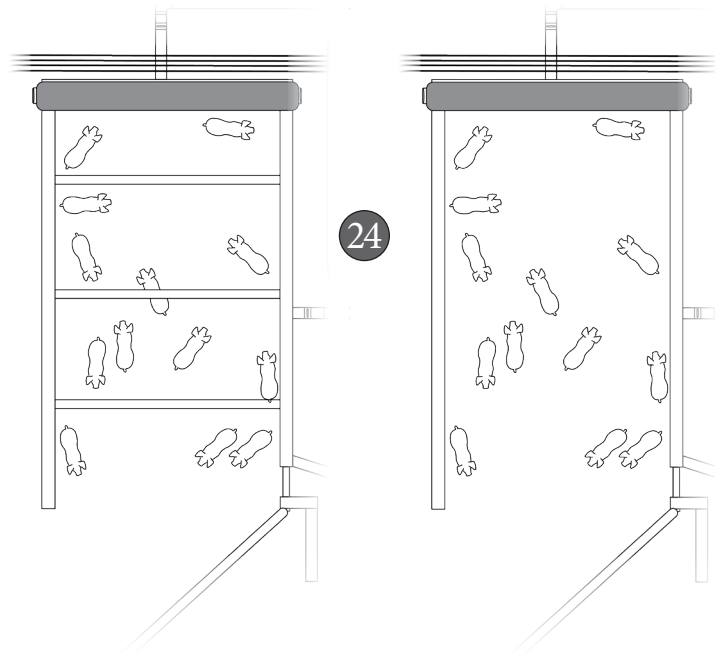

OPERATION INSTRUCTIONS:

HUMANE EUTHANASIA

CONFIRMING DEATH

A staff personnel should be there to assess insensibility via one of the following methods:

- Lack of rhythmic breathing
- Constricted pupils
- No attempts to raise the head (righting reflex)
- Absence of vocalization
- Absence of palpebral/corneal reflex
- No response to painful stimuli

If there is any response to any of the insensibility checks, then the animals should be euthanized via another approved method for the size of the pig. In most cases, the recommendation would be to have a captive bolt gun available for any failures.

COST BREAKDOWN:

Actual depopulation costs during this project

The mass depopulation accomplished by carbon dioxide gas exposure with the pen structure described in this manual cost **\$7.62 per pig**. This assumes total construction costs are leveraged over a minimum of 10,000 market weight pigs. Although the longevity of the facility was not tested in this project, this is certainly well less than the potential lifetime throughput of the facility and equipment.

- This includes facility construction costs of \$4.18 / head.
- This includes 5 total personnel to operate the site that are a mix of hourly laborers and at least one veterinary professional resulting in a labor cost of \$1.03 / head.
- This does include carcass loading and transportation offsite of \$1.81 / head.
- This includes carbon dioxide gas costs of \$0.60 / head that includes cost of gas, rental of tank, delivery and pickup of empty cylinder.
- This does not include the cost to transport live pigs to the site.
- This assumes a daily throughput of 2,333 market weight pigs per day.
- Does not include disposal costs.

Considerations that impact the validity of these costs for future projections

Alternative (and generally preferable) pen/chamber options have been discussed elsewhere that should be coupled with the carbon dioxide vaporization and administration equipment described in this manual and detailed in the “RECOMMENDATIONS FOR STOCKPILE PREPARATION IN THE STATE OF IOWA” section on pg. 26. Using the same assumptions for throughput above (2,333 pigs per day and initial build costs leveraged over 10,000 pigs) the facility construction costs for the carbon dioxide vaporization and administration equipment is \$1.78/head.

The pen structure that was built relied heavily on wooden materials including treated support posts and walls. Over the timeframe from May 7, 2020 to May 7, 2021 commodity wood prices rose from \$332 per linear board foot to \$1686 per linear board foot for an increase of 508%. Concrete costs rose during this timeframe, albeit less. The costs described in this project reflected the low end of that spectrum, future prices, especially depending on global conditions, could increase cost by as much as \$13.05 per head.

The pens were constructed in this project and operated at a height of 54 inches. From observations of this project and others, it is apparent that 40 inches would be a sufficient height. This reduces the needed gas volume by 25% and the associated cost at the time of this project by \$0.15 per head.

We obtained carbon dioxide liquid in 180L tanks that weighed 400lbs. Each tank provided sufficient carbon dioxide gas to depopulate one full semi-trailer load of pigs. This means that each load of pigs

COST BREAKDOWN:

incurs tank rental, delivery and retrieval fees in the project reported here. Sustained throughput would allow carbon dioxide to be obtained in more cost-effective quantities and potentially lower cost. However, it should be noted that this is not a large portion of the per head cost, and rumors of carbon dioxide shortages, although not experienced, occurred throughout the project period.

Future costs employing this pen structure could reasonably be expected to range from \$7.47 to \$20.67 per head, excluding carcass disposal costs.

PERFORMANCE EXPECTATIONS:

The original carbon dioxide vaporization strategy directly from the liquid carbon dioxide tanks to the AgBag as a gas holding system with an in-line fan system blowing the gas back to the pigs performed adequately during the euthanasia phase but the vaporization of the carbon dioxide gas was too slow and limited throughput for the system. Further, the AgBag storage approach was inefficient in terms of gas use because volumes were not controlled directly. Finally, the AgBag was subject to weather impacts and verminous incursion that rendered it useless due to perforation within a few days. The evolution to the system described here provided a much more robust and efficient system. The following average performance parameters were measured:

Time to vaporize gas from liquid source to low pressure (LP) tanks (tested at ambient temperatures of 88°F and 41°F): 18.5 minutes (Performance has not been tested outside of the temperature range)

Time to load live pigs from trailer to pen: 10 minutes

Number of pigs per pen: 86 (95 = maximum capacity)

Time from gas start to increase in vocalization: 2.5 minutes

Time from gas start to last vocalization: 11 minutes

Dwell time (period between last vocalization and opening of pen): 10 minutes

Number of animals that demonstrated signs of life or required additional euthanasia steps: 0

Time required to remove carcasses from pens (using one skid steer and grapple bucket): 19.5 minutes

Average total interval between pens of pigs: 50.5 minutes

Given that the two pens can be alternated, and the recharge time for vaporizing the liquid carbon monoxide is less than half the time that an individual pen is occupied by pigs or carcasses, the pen turnover activities (loading, gassing, dwell time and carcass removal) are the rate limiting steps of this system. Given that two pens represent a typical truckload (up to 190 market hogs with the described pens), a truck load could be depopulated every 50.5 minutes. In a twelve-hour work day, 14.25 truckloads could be depopulated for a total of 2,708 animals.

RECOMMENDATIONS FOR STOCKPILE PREPARATION IN THE STATE OF IOWA:

Carbon dioxide is a feasible option for mass depopulation with advantages of scalability, portability, reliability and robust simplicity. As such, it could be deployed rapidly if key components were acquired ahead of the need and stockpiled. While the number of mass depopulation sites or mobile units is difficult to predict, the following represents the minimum equipment to have for each depopulation unit and the most recent cost estimate:

RECOMMENDED SUPPLIES FOR STOCKPILE PER UNIT

Item	Quantity	Unit Cost	Total
Carbon Dioxide Vaporizer (passive) - 2000 SCFH	1	\$ 1,500.00	\$ 1,500.00
1000 Gallon Propane Tanks	4	\$ 1,650.00	\$ 6,600.00
Insulated Concrete Construction Tarps	2	\$ 1,341.15	\$ 2,682.30
120" Cryogenic Hose	1	\$ 461.24	\$ 461.24
72" Cryogenic Hose	3	\$ 351.13	\$ 1,053.40
CO ₂ Personal Safety Monitors	5	\$ 380.00	\$ 1,900.00
Fittings, Pipe, Valves, Bushings		\$ 3,570.43	\$ 3,570.43

Total cost per depopulation unit \$ 17,767.37

The animal holding pen / container can, and has in other demonstration projects, been built from a variety of commonly available vessels including dump trucks, trash dumpsters, cargo containers, and portable penning with plastic sheeting. Efficiency, throughput and animal welfare are improved if container size is specific for the age and size of animals that need euthanasia. Given these two considerations, it is expected that appropriate pens/containers can be located and modified appropriately for service quickly at the time of need. The tarps specified here provide adequate closure for open top vessels and are therefore recommended for inclusion in the stockpile. Fittings, pipes, valves and bushings are not purpose-built pieces and are readily available in most hardware and home improvement box stores. However, it would improve response time to have those pieces acquired before the need. The remaining items are specialty equipment, require some lead time to acquire, or may be in high demand relative to supply in a widespread depopulation circumstance such as a foreign animal disease and should be acquired and stockpiled before the need.

DISCUSSION / OBSERVATIONS:

Carbon dioxide administration in this system is managed using known volumes and monitoring changes in pressure rather than measuring direct flow rates or carbon dioxide concentrations. This approach provides a reliable and repeatable outcome without dependence on fragile, expensive and hard to procure specialized equipment. An understanding of Boyle's Law guides the use of changes in pressure to monitor this system. Boyle's law can be expressed as an equation that allows for the calculation of the change in pressure expected as the volume of the carbon dioxide changes. Note that this equation uses absolute pressure (which would require consideration of atmospheric pressure) while most common pressure gauges normalize atmospheric pressure to read "zero." In this case, the end point is the animal chamber volume at 0 PSIG of pressure. If we vaporize the gas into a different, smaller volume container (in this case, 1000-gallon LP tanks) we can calculate what pressure it should generate. Measuring pressure (in this case 'gauge pressure') confirms that we have the appropriate amount of carbon dioxide gas vaporized to fill the animal chamber from the LP tanks. These calculations require the following assumptions:

- All calculations are made for empty pig chambers – volume not reduced for pig occupancy which creates a safety margin.
- Waste of gas may occur but assumed to be < or = volume occupied by pigs.
- Boyle's law applies ($P_1V_1 = P_2V_2$).
- All LP tanks (4) charged for one pig chamber at a time.
- Average barometric pressure is ~29.86 inches mercury in this region, 1 inch mercury = 0.4911 psi, and barometric pressure is therefore, 14.66 psi.
- 1000 gallon propane tank is ~41" (D) x ~192" (L).
- Volume of 1000 LP tank is 134.8 cubic feet (1 cylinder with R=20.5" x L=151" PLUS 1 sphere with R=20.5").
- At the end of the process, BOTH the LP tanks and the pig chamber are filled with gas so the final volume includes both of them.

The functional equation then is:

$$(\text{volume of chamber} + \text{LP tanks}) * (\text{pressure in chamber and LP tanks}) = (\text{volume of LP tanks alone}) * (\text{pressure in LP tanks})$$

The following measurements are for the system described in this manual:

$$\begin{aligned} \text{volume of chamber} &= (40' \text{ long} \times 10' \text{ wide} \times 4.5' \text{ tall}) = 1,800 \text{ cubic feet} \\ \text{pressure in the chamber (and LP tanks after discharge)} &= 14.66 \text{ PSI (which would be atmospheric} \\ &\text{pressure, 0 PSIG and read "0" on a gauge)} \\ \text{volume of the LP tanks (4 tanks} &\times 134.8 \text{ cubic feet)} = 539.2 \text{ cubic feet} \\ \text{Pressure in the LP tanks} &= \text{"target pressure"} \end{aligned}$$

DISCUSSION / OBSERVATIONS:

Substituting into the equation:

$$\begin{aligned}(1800 + 539.2 \text{ cu ft}) * (14.66 \text{ PSI}) &= (539.2 \text{ cu ft}) * (\text{target pressure}) \\ 34,292.7 &= (539.2) * (\text{target pressure}) \\ 34,292.7 / 539.2 &= 63.6 \text{ PSI} = \text{target absolute pressure}\end{aligned}$$

Recall that this is absolute pressure (PSI) and the gauges in the system are zero referenced against ambient air pressure so we need to subtract the atmospheric pressure to get the correct target pressure gauge reading (PSIG):

$$63.6 \text{ PSI} - 14.66 \text{ PSI} = 48.9 \text{ PSIG}$$

In this project, we also added the volume of the PVC piping between the LP tanks and the discharge valve from the LP tanks. This leads to a functional operating target pressure of 55 PSIG. This pressure was 100% effective during animal testing.

It can be inferred from the discussion above that there are at least two potential opportunities for improved efficiency of carbon dioxide use which may be important in situations where a widespread pandemic impacts carbon dioxide production, capture, or delivery. First, removing the volume of the animals in the chamber from the equation (since that space does not need to be filled with gas) and recalculating would allow for less gas to be used in each cycle. In our case, we were focused on the humane handling of animals rather than gas use efficiency. Estimating the volume occupied by the animals was beyond the scope of the project so we accepted the inefficiency and used excessive gas to protect animal welfare. Second, in a fixed, two pen system, it would be possible to recapture the carbon dioxide gas used in the first pen for use in the second pen by pumping it directly into the second pen before opening the first. This would require some mechanism to measure carbon dioxide concentration directly and supplement it 'on demand' from the vaporized gas in the LP tanks. Given the cost and procure challenges of equipment to measure carbon dioxide gas concentration directly in air, this proved beyond the scope of the project and system presented here. However, in a nationwide pandemic or foreign animal disease response, these measures might warrant further consideration.

Ambient temperature has an impact on the vaporization rate of the liquid carbon dioxide gas with cooler temperatures having the potential to slow the process. In this project, there was little to no noticeable change down to 41°F ambient temperature. Solid carbon dioxide vaporizes directly into the gaseous state at -110.2°F so colder seasonal extremes could be expected to slow but not prevent the vaporization process described here.

It was possible to impede vaporization and charging of the LP tanks by supplying liquid carbon dioxide to the passive vaporizer at too high of a volume. This could be accomplished by fully opening the liquid valve on the carbon dioxide tank. Once this occurred, dry ice built up at the entrance to vaporizer and stopped the process. This can be prevented by only opening the liquid valve enough so that liquid movement is heard to start. Also, the vaporizer can be monitored externally for frost. Once frost covers

DISCUSSION / OBSERVATIONS:

the entire vaporizer and begins to move down the pipeline to the LP tanks, a dry ice plug is likely and the valve opening from the liquid source tank should be reduced.

In the system described here, there was routinely a period of pause in the vaporization activities between groups since vaporization took less time than the pigs occupied the pens/chambers. This allowed any frost or ice buildup to dissipate. If greater throughput efficiencies were achieved, the risk of ice plug in the system would be greater. In that case, adding a second vaporization unit might a preferable alternative.

PHOTO REFERENCES:

Below are images taken from the pilot study.



Attachment to hold wooden boards to support the tarp



Closed animal gate entry



Unloading location



View of closed gate to chamber 1



Attachment to secure gate



View of screw hooks which secure tarp

PHOTO REFERENCES:

Below are images taken from the pilot study.



View of vaporizer and single CO₂ tank



Frosted input and output connections on vaporizer



LP tank piping frosted over



Wooden boards to hold tarp



Back view of the CO₂ chambers



View of all three attachments for wooden boards

PHOTO REFERENCES:

Below are images taken from the pilot study.



Front view of CO₂ chambers



Side view of CO₂ chamber and alleyway



Animal entry gate



CO₂ liquid output



Vaporizer input and output hoses



Pipe protective cover to prevent pigs from blocking CO₂

RESOURCES:

Below are additional resources and contact information.

Chris Rademacher, DVM
cjrsvm@iastate.edu
515-294-8792

Locke Karriker, DVM, MS, Diplomate ACVPM
karriker@iastate.edu
515-294-2283

Justin Brown, BSA, DVM
brownjt@iastate.edu
515-294-4508